

## DRIVEWAY LITE PURE LED LUMINAIRES INSTALLATION INSTRUCTIONS

The Driveway Lite is designed to be mounted flush with the finished level of the concrete driveway, paving or asphalt etc. The flange is removed by using the allen key supplied and the fitting is fixed in the mounting canister by two screws. Place the mounting canister in the desired position. Make certain that there is drainage material around and beneath the mounting canister to stop water building up inside the canister. Run the low voltage cable from the 240v LED driver into the Driveway canister. A waterproof cable connection must be made using a heavy walled adhesive lined heat shrink to prevent water leaking into the cable joint. Remove the Driveway Lite flange using the allen key supplied and adjust lamp to desired angle. Place luminaire into canister and screw into position with screws provided. Replace flange.

### Recommendation:

Run all low voltage cables in flexible conduit for extra protection.  
Use Hunza Cable Joint Kit CJK#150.

It is recommended that high quality lamps are used when replacing lamps.

**WARNING:** Driveway Lite lens must not be covered with any flammable material.

Maximum drive over speed 10 km/hr.

**DO NOT** water blast/jet wash this fixture under any circumstances.

**Stainless Steel Maintenance:** To maintain the finish of 316 stainless steel it is recommended to wash the luminaire with fresh water from time to time to stop salt and corrosive elements building up. If tea staining appears, a commercially available stainless steel cleaner is recommended to remove this. Electro polishing is recommended in this situation but the fitting will still require regular maintenance. Even an electro polished stainless steel fixture under an eave or roof will suffer from the build up of salt deposits as it will not be washed away by rain.

## LED CHANGING

**CAUTION:** Make sure that the power to the luminaire is switched off before attempting to change the lamp. Beware of hot luminaire and lamp.

**Gasket and lens sequence for Driveway Lite:** Place gasket into gasket groove in fitting and put lens on top. Use allen key supplied to tighten the 3 allen head screws to hold the flange in place.

**Note :** If not using a HUNZA™ driver - you must select a suitable constant-current driver. Decide what output is required in mA (350, 700, 1000), the LED requires a forward voltage of 6 vdc.

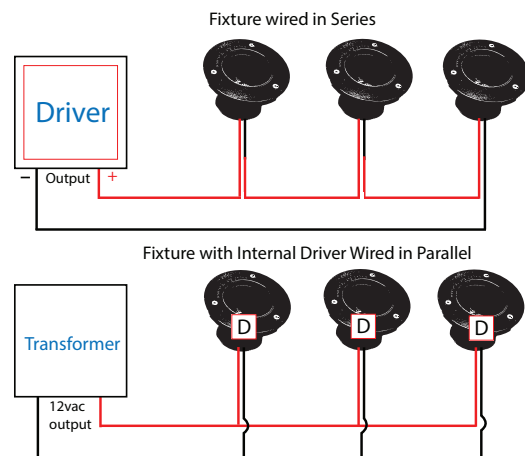

## LAWN LITE LED LUMINAIRES INSTALLATION INSTRUCTIONS

**NOTE: THESE INSTRUCTIONS MUST NOT CONTRAVENE YOUR LOCAL ELECTRICAL AUTHORITY REGULATIONS, WITH WHICH ALL INSTALLATIONS HERE IN MUST COMPLY. PLEASE KEEP INSTRUCTIONS FOR FUTURE REFERENCE.**

The Lawn Lite is designed to be set into the ground. Dig a small hole which aligns the Lawn Lite flange just below the ground level. Run the low voltage cable from the 240v driver to the Lawn Lite. A waterproof cable connection must be made using a heavy walled adhesive lined heat shrink to prevent water leaking into the cable joint. To adjust lamp to desired angle, remove the flange using the allen key supplied.

**Deck Mounting Version** - Cut a 115mm hole in the timber. A waterproof connection must be made using a heavy walled adhesive lined heat shrink, between the supply cable and the fitting. Using the allen key supplied with the luminaire, remove the flange. Screw the luminaire to the timber with the screws supplied. Replace flange onto luminaire.

### Recommendation:

Run all low voltage cables in flexible conduit for extra protection.  
Use Hunza Cable Joint Kit CJK#150.

**WARNING:** Take care to place luminaire in a suitably safe position due to operating temperature of luminaire.

**DO NOT** water blast/jet wash this fixture under any circumstances.

**Stainless Steel Maintenance:** To maintain the finish of 316 stainless steel it is recommended to wash the luminaire with fresh water from time to time to stop salt and corrosive elements building up. If tea staining appears, a commercially available stainless steel cleaner is recommended to remove this. Electro polishing is recommended in this situation but the fitting will still require regular maintenance. Even an electro polished stainless steel fixture under an eave or roof will suffer from the build up of salt deposits as it will not be washed away by rain.

## LAMP CHANGING

**CAUTION:** Make sure that the power to the luminaire is switched off before attempting to change the lamp.

Place gasket into gasket groove in fitting and put lens

**Gasket and lens sequence for Lawn Lite:**

on top. Use allen key supplied to tighten the 3 allen head screws to hold the flange in place.

**Note :** If not using a HUNZA™ driver - you must select a suitable constant-current driver. Decide what output is required in mA (350, 700, 1000), the LED requires a forward voltage of 6 vdc.

