

Floor Lite Louvre

Cat. No. FLLU

Cat. No. FLLUGU



The Floor Lite Louvre has an extremely low profile (3mm) and can be walked upon without damaging the luminaire.

The Louvre flange at a 45 degree angle cuts to illuminate glare. This luminaire is supplied with a mounting canister.

A GU10 version of this luminaire is also available for line voltage lamps.

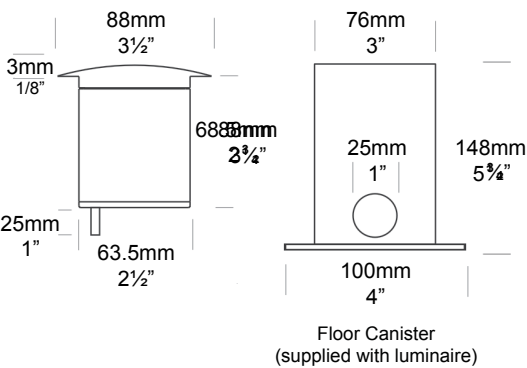

Ordering Information

Luminaire Type	Material	Accessories
FLLU - Floor Lite Louvre	COP - Copper	CJK150 - Cable Joint Kit
FLLUGU - Floor Lite Louvre	SS - Stainless Steel	CANSS - Stainless Steel Canister
GU10		DKCAN - Deck Canister

Ordering Example: FLLU COP - Floor Lite Louvre in Copper
 FLLUGU SS - Floor Lite Louvre GU10 in Stainless Steel
 DKCAN - Deck Canister
 (accessories ordered separately)

Luminaire Construction

CNC machined from one of the following materials

Copper

Body: 63.5mm (2") x 10mm (3/8")

copper tube.

End cap: 63.5mm (2") solid copper rod.

Flange: 90mm (3 1/2") solid copper rod.

316 Stainless Steel

Body: 63.5mm (2") x 10mm (3/8")

stainless steel tube.

End cap: 63.5mm (2") stainless steel

rod.

Flange: 90mm (3 1/2") stainless steel rod.

Mounting

The luminaire is pushed into the canister and is held in by two silicone "O" rings.

CANSS or FLCAN is cast into concrete, brick, tiles, etc.

DKCAN is mounted into wooden decks, wooden frames, etc.

Features

Lens

10mm (3/8") clear tempered shatter resistant glass.

Gasket

Silicone, iron impregnated 220°C (428°F)

Lamp Holders

MR16 & GU10 - 350°C (662°F) ceramic multi contact lamp holder with 250°C (480°F) Teflon cables.

Accessories

Cable Joint Kit (Cat. CJK150). Not approved for USA/Canada.

Stainless Steel Canister (Cat. CANSS).

For use in lime stone, etc.

Deck Canister (Cat. DKCAN).

Standards

EN60598, IP67, UL1838, 

Luminaire Weight

Copper - 1.200kg (2lb 10oz)

Stainless Steel - 0.995kg (2lb 3oz)

Power Supply

Hunza Inground or Wall Mount Transformer: not included.

USA and Canada

Hunza Wall Mount Transformer: not included.

Lamp Options

MR16 - 20 watt lamp max.

GU10 - 25 or 35 watt lamp max.

USA and Canada

MR16 - 20 watt lamp max.

GU10 - lamp not supplied.

HUNZA™ PURE
OUTDOOR
LIGHTING

HUNZA FACTORY
130 Felton Mathew Ave
Glen Innes
Auckland 1072
New Zealand

Ph: 64-9-528 9471
Fax: 64-9-528 9361
hunza@hunza.co.nz
www.hunzalighting.com

INTERNATIONAL CONTACTS:
[http://www.hunzalighting.com/
contact.php](http://www.hunzalighting.com/contact.php)
Specification may change without notice.
Manufactured in New Zealand.
© 2016 Hunza Holdings Ltd.