

Floor Lite Square

Cat. No. FLSQ
Cat. No. FLSQGU

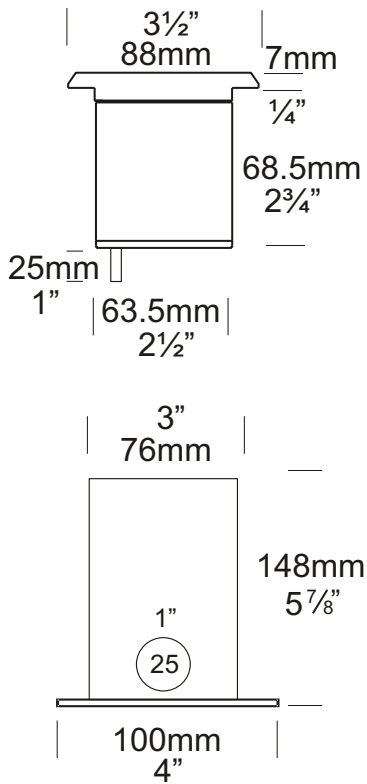

Floor Canister
(supplied with luminaire)



The Floor Lite Square has a 88mm (3½") x 88mm (3½") flange which has an extremely low profile of 7mm (¼") and can be walked upon without damaging the luminaire. The square shape makes it ideal for mounting in tiled areas.

A GU10 version of this luminaire is also available for line voltage lamps.

Ordering Information

Luminaire Type	Material	Accessories
FLSQ - Floor Lite Square	COP - Copper	CJK150 - Cable Joint Kit
FLSQGU - Floor Lite Square GU10	SS - Stainless Steel	CANSS - Stainless Steel Canister
		DKCAN - Deck Canister
		LENSSTEPF - Frosted Lens
		HCL - Hex Cell Louvre

Ordering Example: FLSQ COP - Floor Lite Square in Copper
FLSPSQGU SS - Floor Lite Square GU10 in Stainless Steel
HCL - Hex Cell Louvre
(accessories ordered separately)

Luminaire Construction

CNC machined from one of the following materials

Copper

Body: 63.5mm (2") x 10mm (3/8") copper tube.
End cap: 63.5mm (2") solid copper rod.
Flange: 88mm (3 1/2") x 88mm (3 1/2") square copper bar.

316 Stainless Steel

Body: 63.5mm (2") x 10mm (3/8") stainless steel tube.
End cap: 63.5mm (2") stainless steel rod.
Flange: 88mm (3 1/2") x 88mm (3 1/2") square stainless steel bar.

Mounting

The luminaire is pushed into the canister and is held in by two silicone "O" rings.
CANSS or FLCAN is cast into concrete, brick, tiles, etc.
DKCAN is mounted into wooden decks, wooden frames, etc.

Features

Lens

10mm (3/8") clear tempered shatter resistant glass.

Gasket

Silicone, iron impregnated 220°C (428°F)

Lamp Holders

MR16 & GU10 - 350°C (662°F) ceramic multi contact lamp holder with 250°C (480°F) Teflon cables.

Accessories

Cable Joint Kit (Cat. CJK150). Not approved for USA/Canada.

Stainless Steel Canister (Cat. CANSS).

For use in lime stone, etc.

Deck Canister (Cat. DKCAN).

Frosted Lens (Cat. LENSSTEPF).

Hex Cell Louvre (Cat. HCL).

Standards

EN60598, IP67, UL1838, 

Luminaire Weight

Copper - 1.175kg (2lb 9oz)

Stainless Steel - 1.810kg (3lb 15oz)

Power Supply

Hunza Inground or Wall Mount Transformer: not included.

USA and Canada

Hunza Wall Mount Transformer: not included.

Lamp Options

MR16 - 20 watt lamp max.

GU10 - 25 or 35 watt lamp max.

USA and Canada

MR16 - 20 watt lamp max.

GU10 - lamp not supplied.

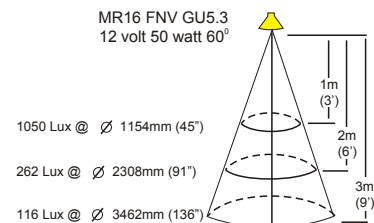
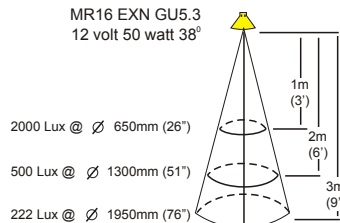
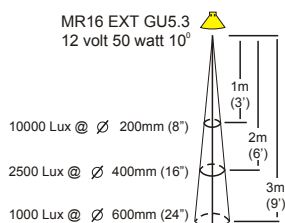
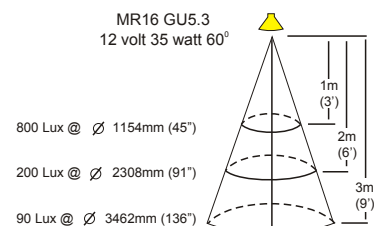
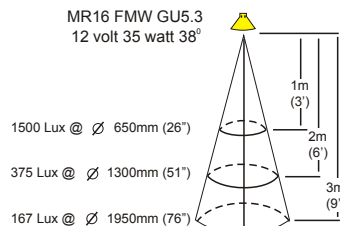
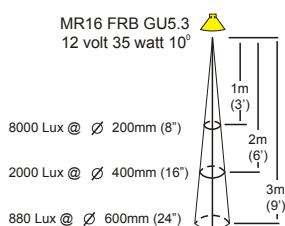
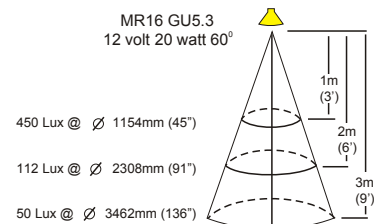
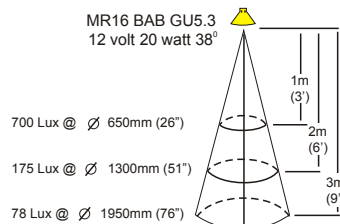
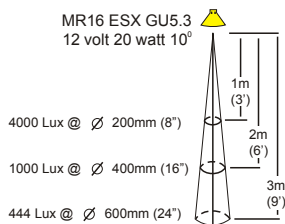

HUNZA™ PURE
OUTDOOR
LIGHTING

HUNZA FACTORY
130 Felton Mathew Ave
Glen Innes
Auckland 1072
New Zealand

Ph: 64-9-528 9471
Fax: 64-9-528 9361
hunza@hunza.co.nz
www.hunzalighting.com

INTERNATIONAL CONTACTS:
<http://www.hunzalighting.com/contact.php>
Specification may change without notice.
Manufactured in New Zealand.
© 2016 Hunza Holdings Ltd.