

Step Lite

Cat. No. SL

Cat. No. SLGU



The Step Lite is designed with a 88mm (3½”) flange for flush mounting into masonry, stone or wood. This luminaire is ideal for illumination of steps and ground level horizontal lighting, for example, across driveways or exterior paved areas. When a canister is used there are no mounting holes in the flange.

A GU10 version of this luminaire is also available for line voltage lamps. However, a longer luminaire body is needed to accommodate the longer lamp.

Ordering Information

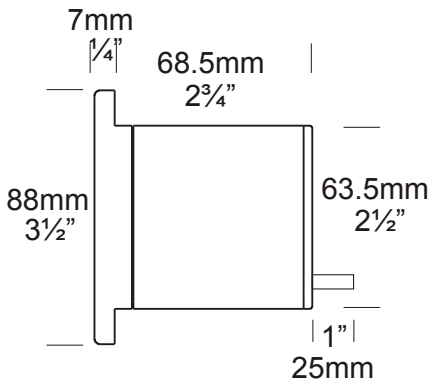

Luminaire Type

SL - Step Lite
SLGU - Step Lite GU10

Material/Finish

BK - Black
BZ - Bronze
CT - Corten
DG - Dark Grey
OG - Olive Green
STAR - Silver Star
WB - White Birch
WH - White
COP - Copper
SS - Stainless Steel

Accessories

CJK150 - Cable Joint Kit
CANSS - Stainless Steel Canister
HCL - Hex Cell Louvre
LENSSTEPF - Frosted Lens
SLCAN - Step Lite Canister

Ordering example: SL BK - Step Lite in Black
SLGU SS - Step Lite GU10 in Stainless Steel
SLCAN - Step Lite Canister
(accessories ordered separately)

HUNZA™ PURE
OUTDOOR
LIGHTING

HUNZA FACTORY
130 Felton Mathew Ave
Glen Innes
Auckland 1072
New Zealand

Ph: 64-9-528 9471
Fax: 64-9-528 9361
hunza@hunza.co.nz
www.hunzalighting.com

INTERNATIONAL CONTACTS:
[http://www.hunzalighting.com/
contact.php](http://www.hunzalighting.com/contact.php)
Specification may change without notice.
Manufactured in New Zealand.
© 2016 Hunza Holdings Ltd.

Luminaire Construction

CNC machined from one of the following metals:

Aluminium

High corrosion resistant aluminium with chromate substrate and high UV resistant polyester powder coat.

Body: 63.5mm (2½") x 10mm (3/8") aluminium tube.

End cap: solid aluminium 63.5mm (2½") rod.

Flange: 90mm (3½") solid aluminium rod.

Colours:

Black, Bronze, Corten, Dark Grey, Olive Green, Silver Star, White Birch, White.

Copper

Body: 63.5mm (2½") x 10mm (3/8") copper tube.

End cap: solid copper 63.5mm (2½") rod.
Flange: 90mm (3½") solid copper rod.

316 Stainless Steel

Body: 63.5mm (2½") x 10mm (3/8") stainless steel tube.

End cap: solid stainless steel 63.5mm (2½") rod.

Flange: 90mm (3½") solid stainless steel rod.

Mounting

Designed to fit through a 66mm (2½") hole and be fixed into position by two screws in the flange.

A Step Lite or Stainless Steel Canister (Cat. SLCAN or CANSS) can be used to maintain the aesthetic look of the flange by eliminating the two screw holes in the flange.

Features

Lens

10mm (3/8") clear flush fit shatter resistant glass.

Lifetime Warranty.

Gasket

Silicone, iron impregnated 220°C (428°F).

Lamp Holder

MR16 & GU10 - 350°C (662°F) ceramic multi contact lamp holder with 250°C (480°F) Teflon cables.

Accessories

Cable Joint Kit (Cat. CJK150). Not approved for USA/Canada.

Stainless Steel Canister (Cat. CANSS).

For use in lime stone, etc.

Hex Cell Louvre (Cat. HCL).

Frosted Lens (Cat. LENSSTEPF).

Step Lite Canister (Cat. SLCAN).

Standards

EN60598, IP66, UL1838, 

Luminaire Weight

Aluminium - 0.465kg (1lb)

Copper - 1.340kg (2lb 15oz)

Stainless Steel - 1.055kg (2lb 5oz)

Power Supply

Hunza Inground or Wall Mount Transformer: not included.

USA and Canada

Hunza Wall Mount Transformer: not included.

Lamp Options

MR16 - 20 watt lamp max.

GU10 - 25 or 35 watt lamp max.

USA and Canada

MR16 - 20 watt lamp max.

GU10 - lamp not supplied.

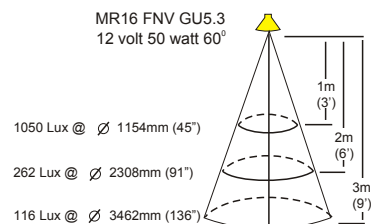
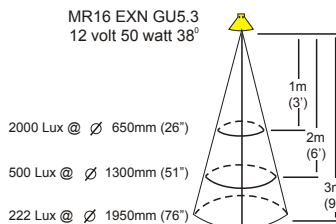
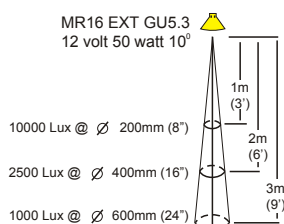
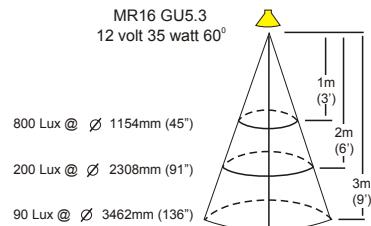
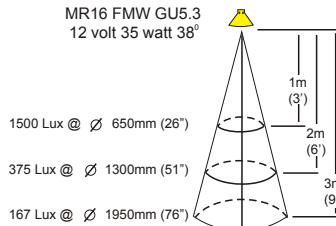
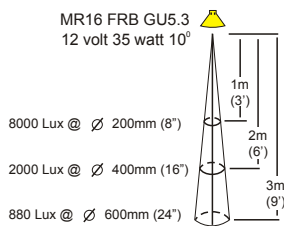
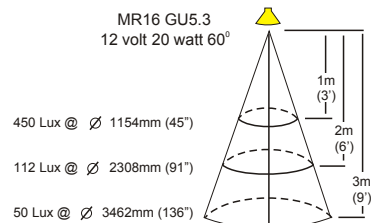
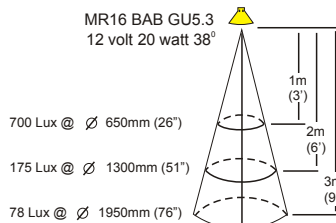
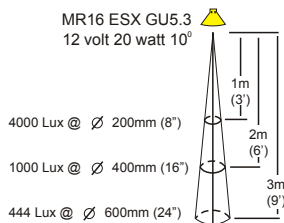

HUNZA™ PURE OUTDOOR LIGHTING

HUNZA FACTORY
130 Felton Mathew Ave
Glen Innes
Auckland 1072
New Zealand

Ph: 64-9-528 9471
Fax: 64-9-528 9361
hunza@hunza.co.nz
www.hunzalighting.com

INTERNATIONAL CONTACTS:
<http://www.hunzalighting.com/contact.php>
Specification may change without notice.
Manufactured in New Zealand.
© 2016 Hunza Holdings Ltd.