

Step Lite Louvre

Cat. No. SLLU
Cat. No. SLLUGU



The Step Lite Louvre has a flush to the surface look with the protrusions. The 45 degree louvers eliminate all upward light, making this luminaire ideal for providing illumination of steps and low level features such as exterior paved areas.

A GU10 version of this luminaire is also available for line voltage lamps. However, a longer luminaire body is needed to accommodate the longer lamp.

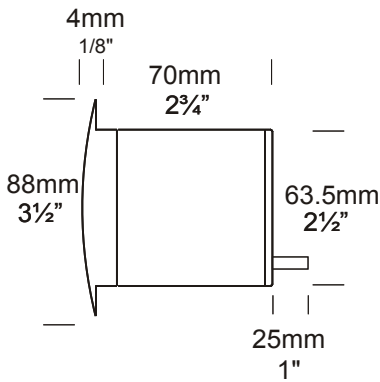

Ordering Information

Luminaire Type

SLLU - Step Lite Louvre
SLLUGU - Step Lite Louvre
GU10

Material/Finish

COP - Copper
SS - Stainless Steel

Accessories

CJK150 - Cable Joint Kit
CANSS - Stainless Steel
Canister
LENSSTEPF - Frosted Lens
SLCAN - Step Lite Canister

Ordering example: SLLU COP - Step Lite Louvre in Copper
SLLUGU SS - Step Lite Louvre GU10 in
Stainless Steel
SLCAN - Step Lite Canister
(accessories ordered separately)

HUNZA™ PURE
OUTDOOR
LIGHTING

HUNZA FACTORY
130 Felton Mathew Ave
Glen Innes
Auckland 1072
New Zealand

Ph: 64-9-528 9471
Fax: 64-9-528 9361
hunza@hunza.co.nz
www.hunzalighting.com

INTERNATIONAL CONTACTS:
[http://www.hunzalighting.com/
contact.php](http://www.hunzalighting.com/contact.php)
Specification may change without notice.
Manufactured in New Zealand.
© 2016 Hunza Holdings Ltd.

Luminaire Construction

CNC machined from one of the following metals:

Copper

Body: 63.5mm (2½") x 10mm (3/8") tube.

End cap: solid copper 63.5mm (2½") rod.

Flange: 88mm (3½") solid copper rod.

316 Stainless Steel

Body: 63.5mm (2½") x 10mm (3/8") tube.

End cap: solid stainless steel 63.5mm (2½") rod.

Flange: 88mm (3½") solid stainless steel rod.

Mounting

Designed to fit through a 66mm (2½") hole and be fixed into position by two screws in the flange.

A Step Lite or Stainless Steel Canister (Cat. SLCAN or CANSS) can be used to maintain the aesthetic look of the flange by eliminating the two screw holes in the flange.

Features

Lens

10mm (3/8") clear flush fit shatter resistant glass.

Lifetime Warranty.

Gasket

Silicone, iron impregnated 220°C (428°F).

Lamp Holder

MR16 & GU10 - 350°C (662°F) ceramic multi contact lamp holder with 250°C (480°F) Teflon cables.

Accessories

Cable Joint Kit (Cat. CJK150). Not approved for USA/Canada.

Stainless Steel Canister (Cat. CANSS). For use in lime stone, etc.

Frosted Lens (Cat. LENSSTEPF).

Step Lite Canister (Cat. SLCAN).

Standards

EN60598, IP66, UL1838, 

Luminaire Weight

Copper - 1.100kg (2lb 6oz)

Stainless Steel - 1.055kg (2lb 5oz)

Power Supply

Hunza Inground or Wall Mount

Transformer: not included.

USA and Canada

Hunza Wall Mount Transformer: not included.

Lamp Options

MR16 - 20 watt lamp max.

GU10 - 25 or 35 watt lamp max.

USA and Canada

MR16 - 20 watt lamp max.

GU10 - lamp not supplied.

Step Lite Louvre Lux MR16 BAB 20 watt lamp - Lens height 400mm (15¾")

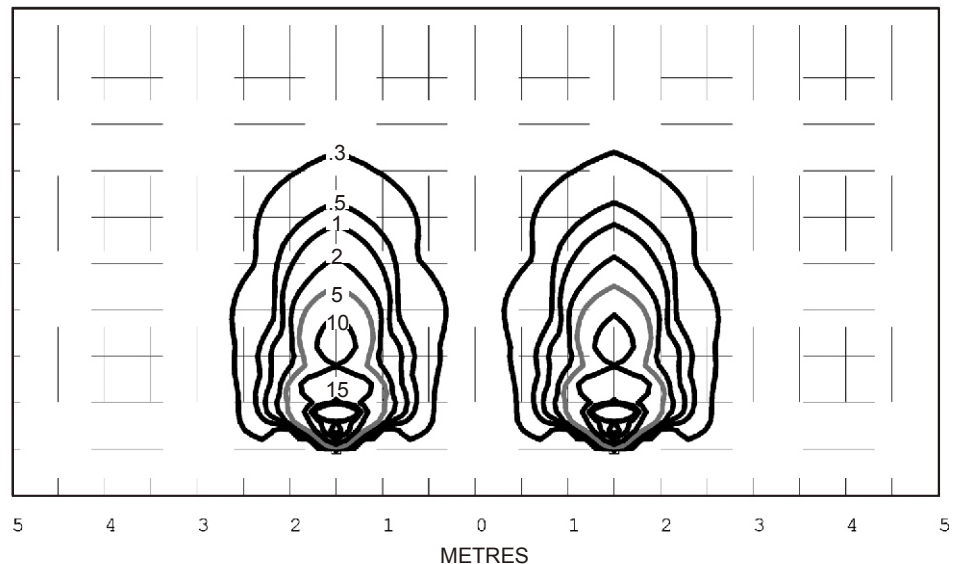
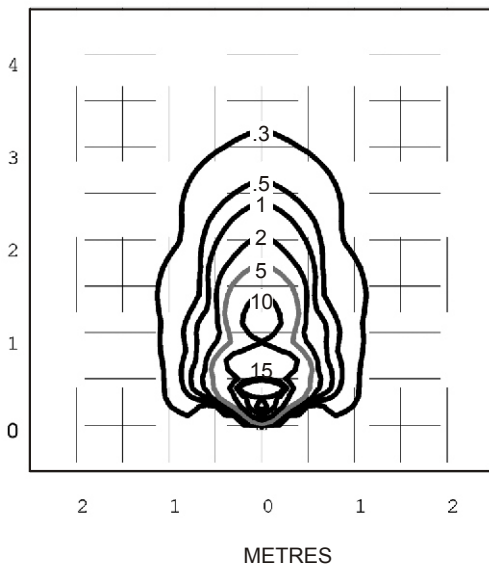

Isolux Lumens Plot - Footcandles = Isolux figures divided by 10.76

HUNZA™ PURE
OUTDOOR
LIGHTING

HUNZA FACTORY
130 Felton Mathew Ave
Glen Innes
Auckland 1072
New Zealand

Ph: 64-9-528 9471
Fax: 64-9-528 9361
hunza@hunza.co.nz
www.hunzalighting.com

INTERNATIONAL CONTACTS:
[http://www.hunzalighting.com/
contact.php](http://www.hunzalighting.com/contact.php)
Specification may change without notice.
Manufactured in New Zealand.
© 2016 Hunza Holdings Ltd.